

DANIELS FOOD EQUIPMENT

AFMG 50 MIXER / GRINDER

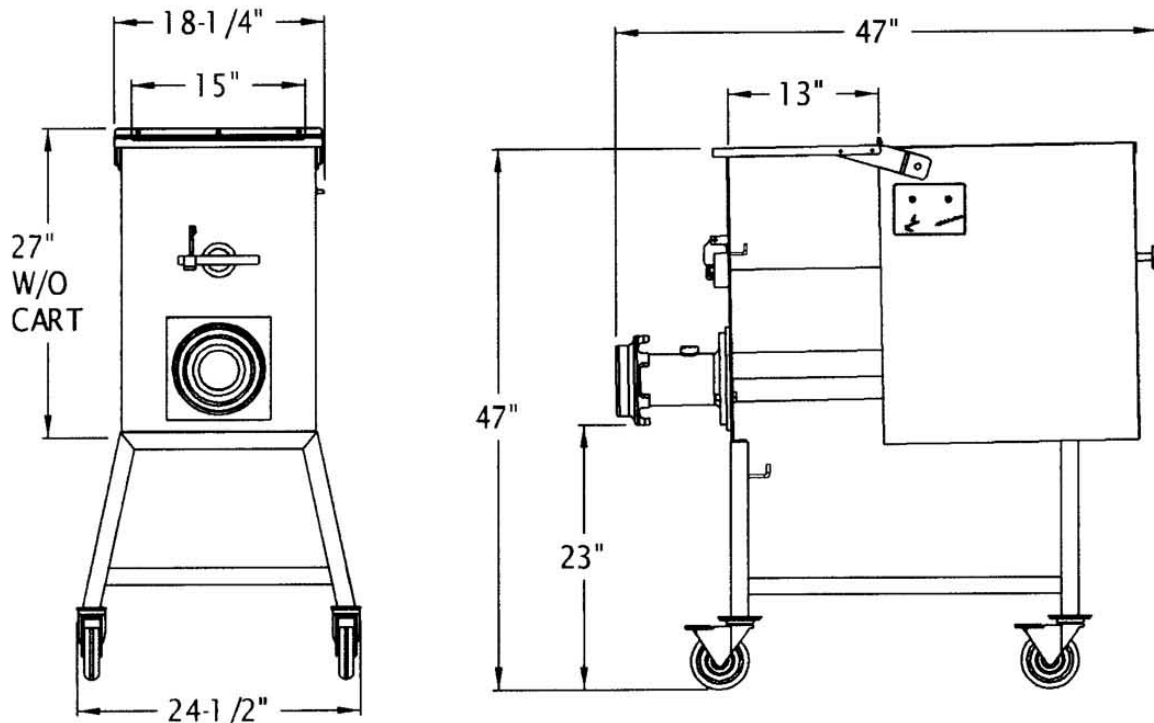

SPECIFICATIONS

- STANDARD:** GRINDER, 230 VOLT, 8.2 AMP, 60 Hz, 3 HP, 3 PHASE.
MIXER, 230 VOLT, 1.9 AMP, 60 Hz, 1/2 HP, 3 PHASE.
- OPTIONAL:** GRINDER; 460 VOLT, 4.1 AMP, 60 Hz, 3 HP, 3 PHASE.
MIXER; 460 VOLT, .95 AMP, 60 Hz, 1/2 HP, 3 PHASE.
230 VOLT, 1 PHASE, 29.8 TOTAL AMP DRAW.
460 VOLT, 1 PHASE, 26 TOTAL AMP DRAW.
- CONSTRUCTION:** HEAVY GAUGE STAINLESS STEEL CONSTRUCTION,
75 LBS. CAPACITY, REMOVABLE PADDLE, STAINLESS
STEEL HOPPER COVER WITH SAFETY LOCKOUT.
- WORKING CAPACITY:** 75-LBS.
- WEIGHT:** 355 LBS. NET, 395 LBS. SHIPPING WEIGHT.
- OUTPUT:** UP TO 100 LBS. PER MINUTE WITH 3/8" PLATE.
- OPTIONS:** MACHINE CART, SINGLE TUB DOLLY, HOPPER FUNNEL.

P.E.N., Inc dba

DANIELS FOOD EQUIPMENT

310 NORTH CLAYBORN AVE. PARKERS PRAIRIE, MN. 56361 PHONE: (218) 338-5000 FAX (218) 338-5909.

WEB: www.danielsfood.com

E-MAIL: danielsfood@midwestinfo.net

7/9/2004